

DC Voltage Measuring Amplifier with Data Logger GM80-TG



Performance Features

- Three trigger inputs for external control
- Bus-capable and addressable RS232
- Data logger up to 3000 meas. values
- Fast measurement up to 1000/s
- Active or passive sensors
- Display of physical unit
- 10 sensor parameter sets
- Fast limit values
- Min./max. memory
- Time and date

Application

- Research and development
- Process measuring and control technology
- Automotive engineering
- Energy and environmental technology
- Mechanical engineering

Description

The GM80-TG processes strain gauge signals from sensors of ± 3.3 mV/V and active signals of ± 5 V and 0/4 ... 20 mA.

A high measuring accuracy combined with fast measuring rates is ensured by the employment of highly precise amplifiers and components, 16 Bit A/D converters and a fast μ -controller.

A versatile configurable data logger stores a series of measurements with date and up to 3000 measured values.

Measured values or logging values can be expelled to a computer by the RS232 interface.

Ten parameter sets are available for sensors. Therein, in each case, the calibration data, the sensor designation and physical unit are deposited.

Functions such as tare, fetch min./max. and delete min./max. are available during the measurement.

By three optocouplers control inputs functions such as data logging, issue of interface, delete buffer, tare or second limit value set can be addressed externally.

By most modern Photo MOS relays, fast switching times and high life spans at the limit values are ensured.

Technical Data

DC Voltage Measuring Amplifier with Data Logger GM80-TG

Type	GM80-TG
Article-No.	107541
Measuring accuracy	0.1 % full scale ± 1 digit
Measuring rate adjustable	1; 10; 100; 1000/s
Display rate	5/s
Display scope	$\pm 9999 + 3$ digits for unit
Zero point adjustment	automatically/manually
Sensor parameter sets	10
Supply desktop mains adapter ¹	100 ... 240VAC
Output desktop mains adapter	24VDC, 1.25 A
Supply voltage GM80-TG	16 ... 30VDC
Current consumption	≤ 250 mA (at 16V)
Logger mode	window, diagram, hand, auto
Memory values	max. 3000
Switching current/voltage limit values	400 mA / 60V
Switching time	≤ 3 ms
Transfer RS232	2400, 4800, 9600, 19200, 38400, 115200 Baud
Addressable devices	1 ... 16
Bridge resistance of strain gauge	350 ... 2000 Ω
Input sensitivity passive	± 3.3 mV/V
Input sensitivity active	± 5 V
Input sensitivity current	0/4 ... 20 mA on 75 Ω burden
Current connection	2 or 3 wire technique
Excitation voltage passive	5V, 20 mA
Supply voltage active	± 12 V, each 100 mA (± 12 V combined max. 120 mA)
Electrical connection	D-SUB socket, high density, 15-pin D-SUB socket, 9-pin for RS232 BMS male connector (D-SUB male connector, 15-pin) 24VDC power supply socket for coaxial connector 2.1 mm
Rated temperature range	15 ... 35 °C
Operating temperature range	5 ... 45 °C
Storage temperature range	-10 ... 70 °C
Dimensions (L x W x H)	160 x 76 x 134 mm
Housing color	white
Level of protection	IP40
Weight	500 g

¹Desktop mains adapter in scope of delivery

Pin Assignment

15-pin		
Pin 1	Ground (supply 5V and 12V)	0V
Pin 2	+12V (supply for active sensors)	12VDC
Pin 3	NC	-
Pin 4	NC	-
Pin 5	NC	-
Pin 6	Ground	0V
Pin 7	NC	-
Pin 8	Supply	5VDC
Pin 9	NC	-
Pin 10	Control signal	L <2.0V; H >3.5V
Pin 11	Signal (+) (active or passive sensors)	mV/V; ±5V; ±10V; 0/4 ... 20 mA
Pin 12	Signal (-) (connect to ground when active sensors)	0V
Pin 13	Shielding	shield
Pin 14	NC	-
Pin 15	NC	-

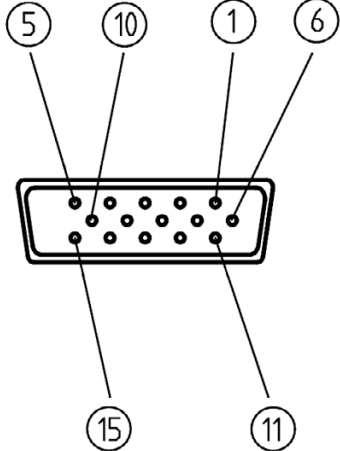

Attention: Do not use pins that are not used! These are used factory-side.

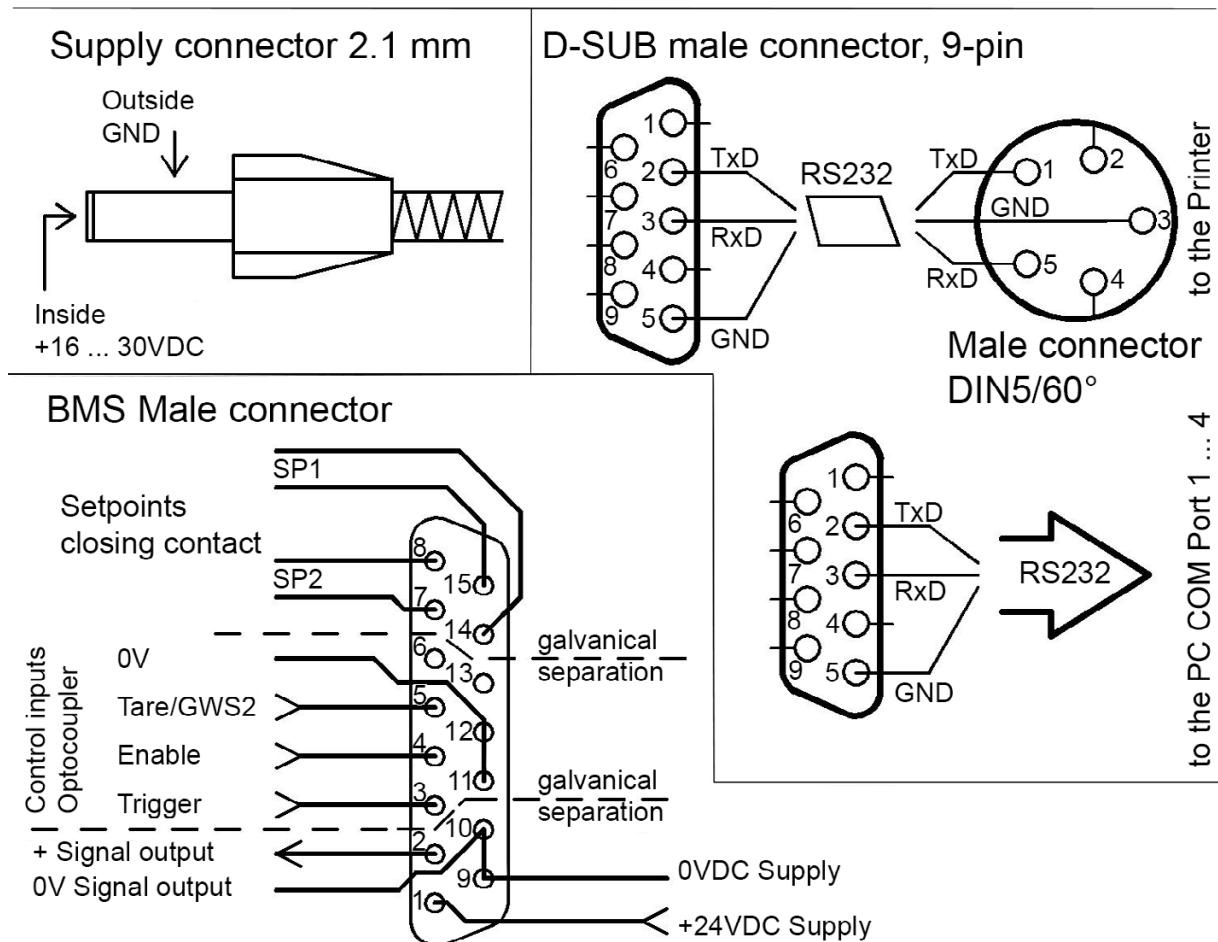

+ Signal output corresponds to a signal output voltage of $\sim 2.5V \pm \sim 2.4V$. The voltage swing ($\pm \sim 2.4V$) and the zero point are depending on the connected sensor. Under load, the voltage swing can be measured with nominal value and at unloaded sensor, the voltage value in the zero point.

Options / Equipment

Article-No.	Description	Type
115134	Adjustment amplifier with simulator	mV/V / $\pm 10V$ / 0/4 ... 20mA
113259	RS232 D-SUB extension, 1:1, 1.8 m, with 9-pin connector and female connector	GM80/D-SUB
109629	RS232 - USB serial interface, 1 m	GM80/USA-19HS
118187	Complete set of mating plugs	GM80-TG/KIT
10477	Connection cable for passive sensors, 3 m, with 5-pin female cable connector and 15-pin D-SUB male cable connector	KDM5/A-KSSH15/A-3m/PVC
10365	Connection cable for passive sensors, 3 m, with 7-pin female cable connector and 15-pin D-SUB male cable connector	KDM7/A-KSSH15/A-3m/PVC
10269	Connection cable for passive sensors, 3 m, with 6-pin female cable connector and 15-pin D-SUB male cable connector	KD6/A-KSSH15/A-3m/PVC
10312	Connection cable for passive sensors, 3 m, with 12-pin female cable connector and 15-pin D-SUB male cable connector	KD12/A-KSSH15/A-3m/PVC
118093	Connection cable for active sensors, 3 m, with 8-pin female cable connector and 15-pin D-SUB male cable connector	KDM8/A-KSSH15/A-3m/PVC
10268	Connection cable for active sensors, 3 m, with 12-pin female cable connector and 15-pin D-SUB male cable connector	KD12/B-KSSH15/A-3m/PVC

Calibrations mV/V²

Article-No.	Description	
401010	Proprietary calibration acc. to ISO 10012	10 steps
401011	Proprietary calibration acc. to ISO 10012	20 steps

² Lorenz-Standard:

- Supply voltage 5V, calibration range ± 1 mV/V in 10 steps, calibration range ± 2 mV/V in 10 or 20 steps
- Language of the Certificate: German and English
- Calibration at DC: Normal K3608, if so display above Keithley 2000 or Lorenz VS3 (Lorenz amplifier with USB interface)
- Calibration at 225 Hz: Normal K3608, if so display above HBM MGCplus + ML38
- Calibration at 225 Hz: Normal BN100A, if so display above HBM DMP40

Configuration and Evaluation Software GM80-VS2

- Convenient configuration and evaluation software
- Graphical representation
- Automatic scaling of the Y-axis
- Read data logger
- Automatic saving of measured values as CSV or BMP file

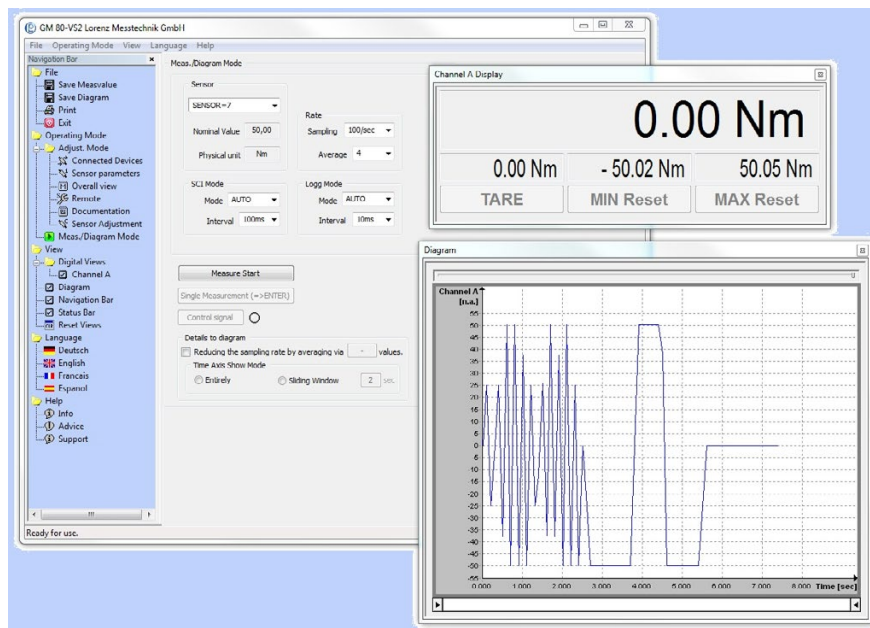

The configuration and evaluation software serves for easy evaluation and graphical visualisation of the evaluated data on a PC.

The software allows direct read-in of measured data into a text file in CSV-format through the serial port of a PC. This enables further analyses with a commercially available spreadsheet program at any time.

Technical data

Type	GM80-VS2 ³
Interface	RS232 / USB
Protocol	ASCII based
System requirements	Windows® 7 - 10 32/64 Bit ⁴ Dual-Core from 1.8 GHz (with diagram)

³ Software/driver download: https://www.lorenz-messtechnik.de/phplogin/login_en/html/software.php

⁴ Windows® is a registered trademark of Microsoft Corporation in the USA and other countries.

All trademarks or brands used in this document are specific to the product or owner of the trademark. Lorenz Messtechnik GmbH does not claim to any other than its own trademarks or brands.

Highlights at a glance

Conversion in physical values	Supported in the device
Graphical display of the measured variables	✓
Automated or manual storage in a CSV or BMP file	✓
Print-out of the diagram with date and definable superscription	✓
Scaling function of the input variable to any display value with unit	✓
Resettable minimum value memory for each measured value	✓
Resettable maximum value memory for each measured value	✓
Floating averaging	Supported in the device
Tara for each measured size	✓